

# CHAFER GUARD ADJUSTABLE SNEEZE GUARD

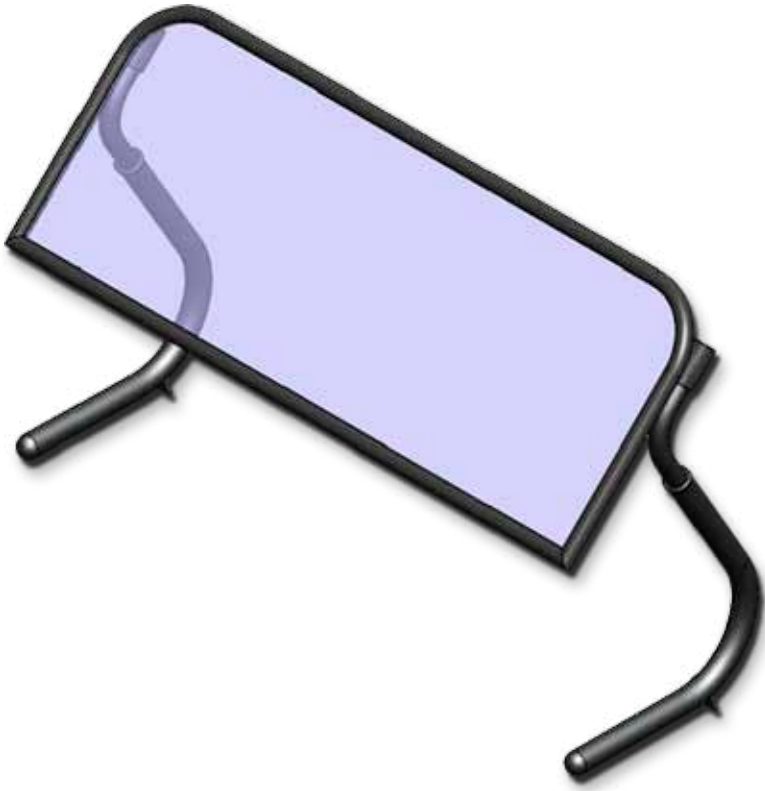

CHAFER GUARD

- *Same “Easy as 1, 2, 3” setup and take down operation.*
- *New telescopic stand design allows guard opening to extend from 13” to 17” in height.*
- *Cost effective - Use one guard for different setups.*
- *Available in 2’ , 3’ , 4’ , 5’ and 6’ lengths.*
- *Black or Rich Gold finish*



ANSI/NSF 2

\* Images are computer renderings, not actual photos, some color variance may occur from what is rendered to the actual powder coat finish.

Phone: 800-569-2056  
Fax: 573-449-7126  
[www.sneezeguardsolutions.com](http://www.sneezeguardsolutions.com)

# SPECIFICATIONS

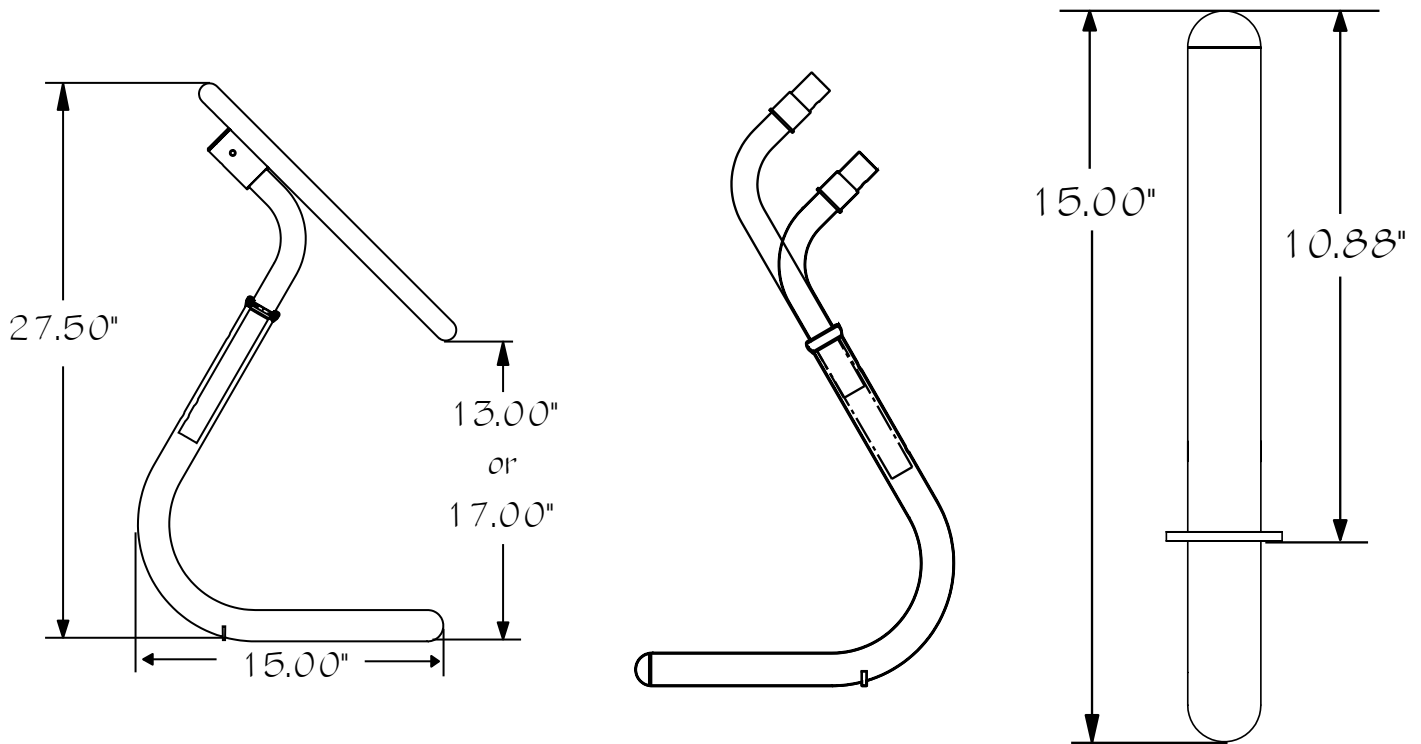

CHAFFER GUARD

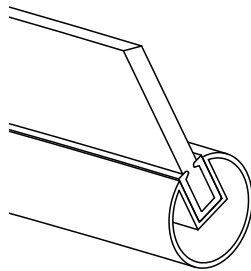

- Exclusive extruded 1" Groove Tube
- Mounted in rubber gasket
- 1.25" aluminum stands
- Scratch resistant acrylic food shield
- Powder coated finish

<i>Black</i>	<i>Gold</i>	<i>Nominal Length</i>	<i>Overall Length</i>	<i>Between Stands</i>	<i>Weight</i>
1921	1922	2 foot*	28"	23.25"	8 lbs
1931	1932	3 foot	37.25"	32.5"	9 lbs
1941	1942	4 foot	46.5"	41.75"	10 lbs
1951	1952	5 foot	58.5"	53.75"	13 lbs
1961	1962	6 foot	70.5"	65.75"	14 lbs
1981	1982	8 foot	84.5"	89.75"	18 lbs

*\*One leg does not lock in a closed position due to short length of guard.*

*Call for quote on substituting tempered glass for Acrylic food shield.*